

***OPERATING & MAINTENANCE
INSTRUCTIONS***

FOR

CHAIN & CHISEL MORTISER

TYPE

M.F

Wadkin

CHAIN AND CHISEL MORTISER M.F.

PRINCIPAL DIMENSIONS AND CAPACITIES

Will take timber up to	12" deep × 9" wide
Maximum size of mortise using chain	1¼" × 3" × 6" deep
Maximum size of chisel	1"
Will bore up to	1" dia. × 5½" deep
Size of table	2' 3" × 8"
Minimum height of table from floor	1' 7½"
Vertical rise and fall of table	10½"
Longitudinal motion of table	2' 0"
Transverse motion of table	4¼"
Horse-power of motor on chain spindle	4
Horse-power of motor on chisel spindle	2
Speed of both motors on 50 cycles in r.p.m.	3,000
Speed of both motors on 60 cycles in r.p.m.	3,600

DETAILS INCLUDED WITH THE MACHINE

- One chain cutter grinder, complete with emery wheel 4" diameter.
- Three pairs of sprockets to carry chains of .54", .62", .89" pitches.
- One set of adapter bushes, comprising one each $\frac{3}{16}$ ", $\frac{1}{4}$ " and $\frac{5}{8}$ " for bits and $\frac{13}{16}$ " and $1\frac{3}{16}$ " for chisels, alternatively $\frac{3}{16}$ ", $\frac{1}{4}$ " and $\frac{13}{16}$ " for bits and $\frac{5}{8}$ ", $\frac{3}{4}$ ", $1\frac{1}{8}$ " for chisels.
- One set of depth stops.
- One driving belt for cutter grinder.
- One set of spanners.
- One lubricating pump and tin of ball bearing lubricant.

CHISEL HEADSTOCK

AUTOMATIC START
AND STOP CONTROL.

OPERATING LEVERS.

CHAIN HEADSTOCK

CHAIN GUARD

CHAIN GRINDER.

EXHAUST FAN

CHIP BREAKER

ADJUSTABLE DEPTH
STOP.

ISOLATING SWITCH.

TABLE CROSS
TRAVERSE

TABLE RISE AND
FALL.

LATERAL TABLE
TRAVERSE

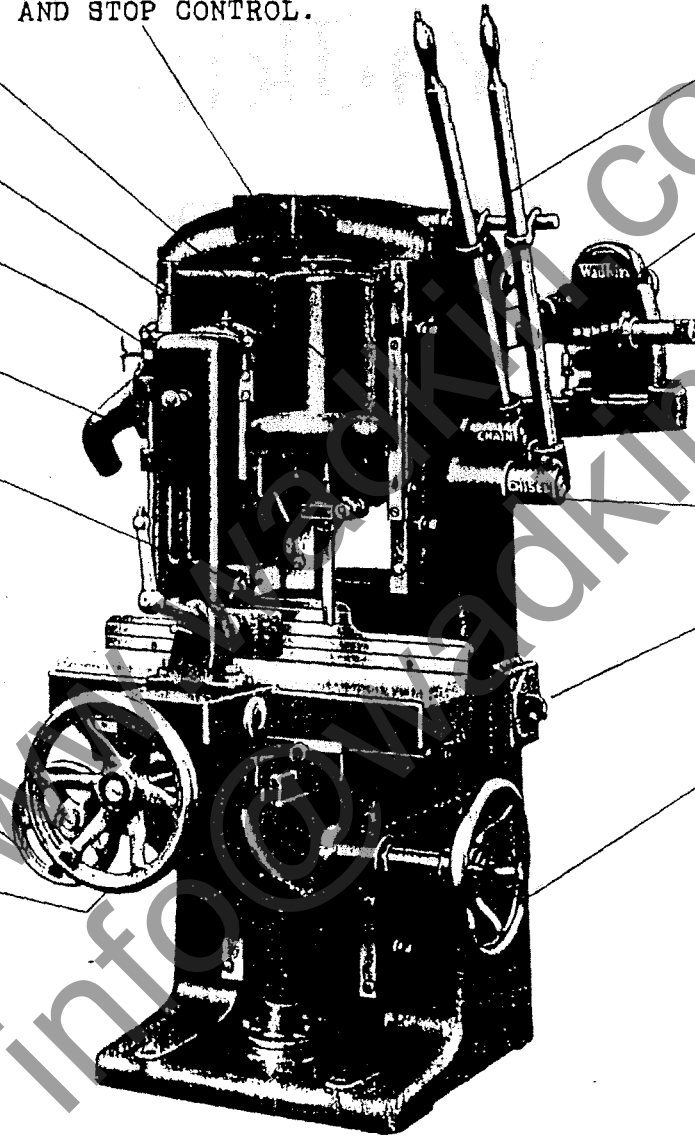

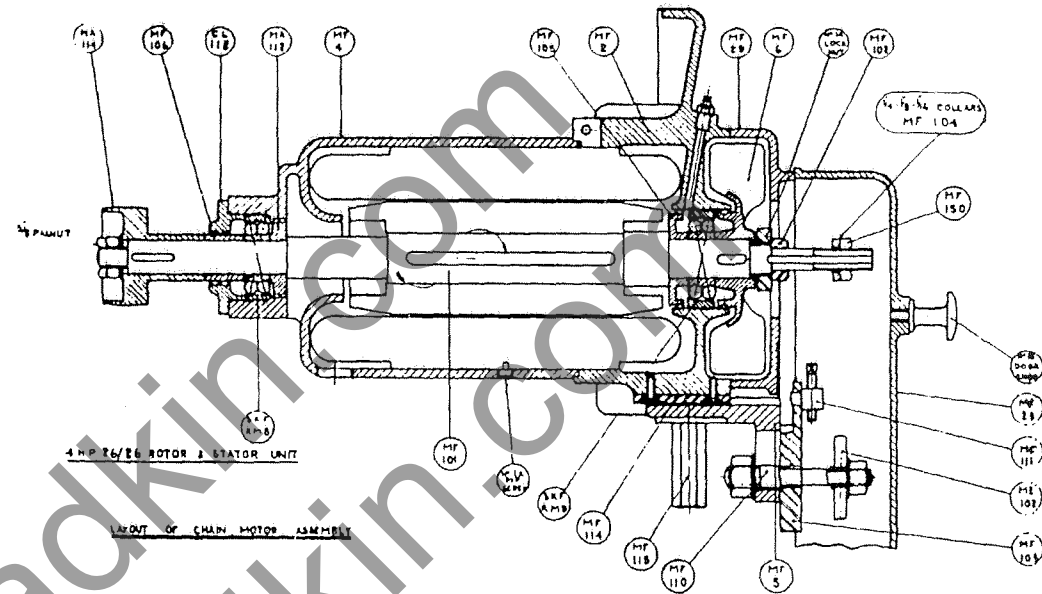
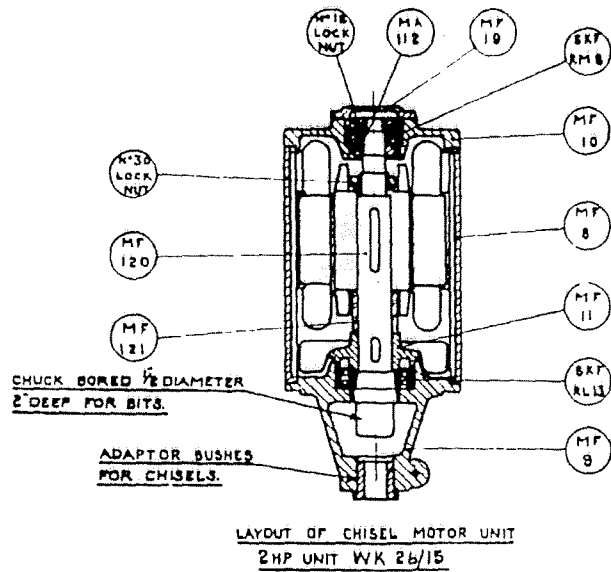

THE MACHINE

The machine is despatched from our Works with all bright surfaces greased to prevent rusting. This must be removed by applying a cloth damped in paraffin or turpentine.

THE MOTORS (See end of booklet for electrical installation).

LUBRICATION

If too much lubricant is applied it is liable to cause the bearings to run hot.

The ball bearings in the motors should be given three depressions with the grease gun every three months.

The two spring-box bearings to be given one depression of the grease gun daily.

All moving parts marked 'oil' at Fig. 1 to be oiled daily.

Use a good quality machine oil, Wadkin grade L.4.

Wadkin grease lubricant grade L.6 is recommended for all ball bearings.

Alternatively the following grease lubricant may be used.

Shell Mex and B.P. Ltd.	Shell NERITA grease 3.
Vacuum Oil Co. Ltd.	GARGOYLE grease B.R.B.3.
Caltex Lubricants	REGAL STARFAK No. 2 grease.

Thoroughly clean down the machine and motors every week.

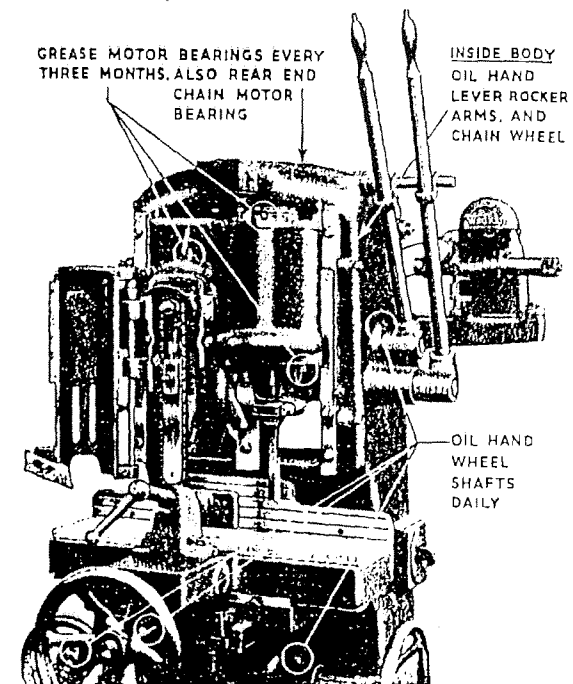

The efficient lubrication of mortise chains during operation has always been a difficulty and therefore we have introduced a greasing arrangement which it is considered will prolong the life of the chain. The improvement incorporates a grease nipple in the Guide Bar and from which the lubricant is carried down the Bar and into the Bottom Roller.

Should the mortise chain be in-operation for a longer period, it is essential to give one or two depressions of the grease gun every half hour. The exact period for lubricating must be decided by the operator. Do not allow the Guide Bar to become hot.

THE TABLE

It is necessary to fit into the full length of metal table a piece of hard wood about $1\frac{1}{4}$ " thick to prevent the mortise from splitting out at the bottom as the chain descends to maximum depth. This must be dead parallel and renewed as occasion arises.

CHAIN MORTISING

The mortise chain should revolve so that the cutting edges descend into the work. Use only the sprocket wheel and guide bar for the corresponding size of mortise required. They are clearly stamped with their size.

Keep the chain adjusted so that it can be pulled away from the bar $\frac{1}{8}$ " as in Fig. 3. A screw "B" is provided above the chain guide bar "C" for adjusting the chain to the correct tension and taking the thrust of the bar. The chain when new should run idle for a few minutes and be readjusted before being put to work. Lubricate about every half hour when in use. Do not force chain into the wood, but feed smoothly. Do not traverse the table whilst the chain is in the mortise. To cut a longer or wider mortise than the chain allows bring chain out of cut and traverse table before making the second cut.

Although the mortise chains are supplied suitable for general work in hard or soft woods, we advise that where wet oak is used, they should be specially ground for this class of work.

The mortise chain can be set dead in line with the chisel or offset to $\frac{1}{16}$ " out of line. The adjustment is made by turning screw "E", Fig. 2, but before making the adjustment first release nuts "F" to bring the chain sprocket into the correct position, four collars are supplied. These are placed behind the sprocket and will give any position rising by $\frac{1}{16}$ " up to the maximum.

COMBINED GUARD AND CHIPBREAKER

To meet Factory Regulations the guard must always rest on the work and rise and fall as the mortise chain is brought into the cut. The locking handle on the hinge spindle adjusts the movement of the guard according to the depth of timber being mortised. The wood chipbreaker must be close to the chain at all times and ride on the top face of the work in order to avoid splitting the top edge of the mortise. The chipbreaker should be made in hard wood and renewed when necessary.

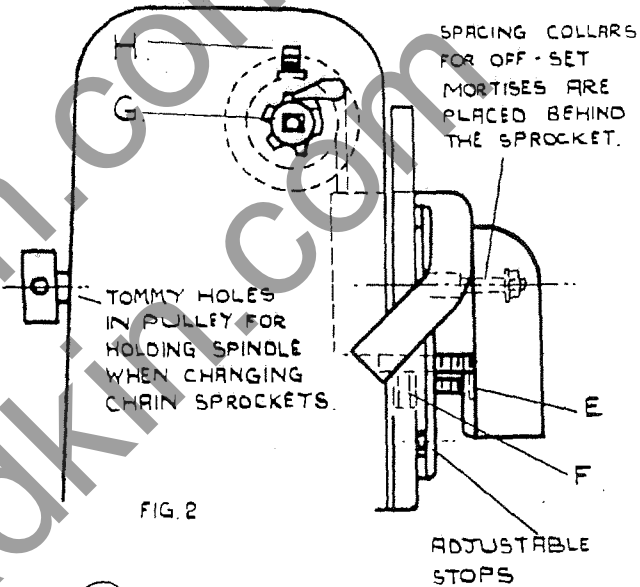

FIG. 2

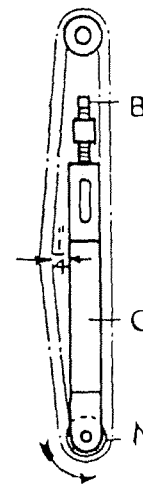

FIG. 3.

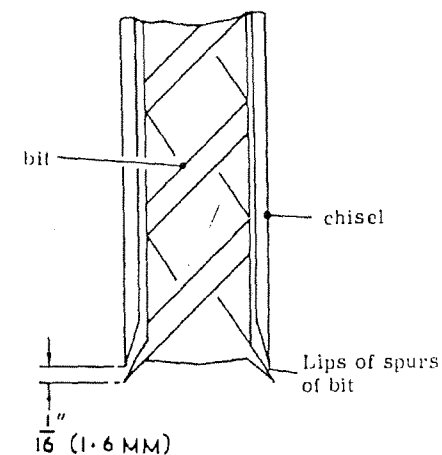

FIG. 4

FAN

The chips can be deposited into a cyclone placed behind the machine. A flexible pipe connecting the fan outlet to the cyclone. Where a pneumatic system for clearing away the chips is installed the fan outlet may be connected to it by means of a flexible pipe.

BALANCE OF HEADSTOCKS

Both headstocks are balanced by spring arrangements which are set before the machine leaves our Works. Should it be necessary to remove or adjust the springs the following instructions must be observed. Take care to prevent the headstock from falling by bringing it into contact with one of the adjustable stops. The spring boxes are attached to spindles "G," Fig. 2. To obtain correct tension to the spring for controlling the headstock give a partial turn to the ratchet by a spanner on the spindles "G." The ratchet on the left-hand side operates the chain headstock and the one on the right the chisel headstock. To test the spring pull down the hand lever a few times and if the motor works freely up and down then the spring is correctly tensioned. If, however, more tension is required give a further partial turn to the ratchet and finally lock tight screw "H."

SQUARE CHISEL MORTISING

The lips or spurs of the bit should not be allowed to touch the cutting edge of the chisel but should be set $\frac{1}{16}$ " (1.6 mm) below the chisel points, as shown in fig. 4, so that the bit cuts before the chisel. Both the chisel and bit must be a good fit in the machine. Do not jerk the tool into the wood, but give steady pressure. Withdraw the tool occasionally from the work to allow the bit to clear itself of the chips. A set of bushes is supplied sufficient to take the full range of Wadkin square chisels and bits up to the capacity of the machine.

HAND LEVERS

Are placed on the right-hand side of the machine for bringing either chain or chisel into operation. After completing the cut, the hand lever should be brought into the neutral position (located by spring catch) and thus automatically stop the tool by engaging with the "Stop Button."

STOPS

Stops for regulating the depth of mortise to be cut are attached to the main slides.

AUTOMATIC STOP ATTACHMENT

Stop carriage is secured to machine table by screws inserted through holes provided in fence. The revolving stop bar is secured to table in hole in the side of fence extension of table, and the locknuts adjusted to enable stop bar

to rotate freely, but without any end play. The steel ball, spring and grubscrew are inserted in hole under the boss carrying stop bar. The steel ball will then locate stop bar in any of its four positions. Dead stop is fitted in hole "L," as shown.

The spring stops are set on the long bar to locate the position of each mortise to be cut. Before making the cut the table is set over to dead stop "K." If a longer mortise is required than cutter will give at one stroke, the stops "M" on stop bar must be set accordingly. Four varying lengths can be provided by rotating stop bar. Each stop is brought into position to give required length of mortise in conjunction with dead stop.

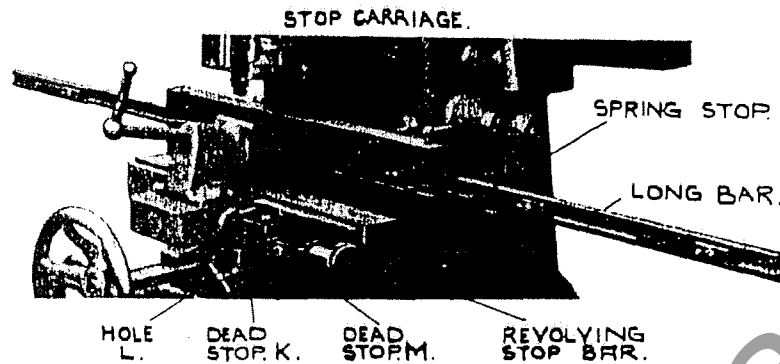

GIVE TWO DEPRESSIONS OF THE GREASE GUN EVERY SIX MONTHS

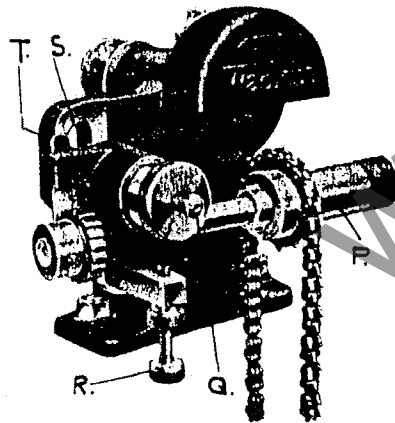

FIG. 6.

UPKEEP OF TOOLS

It is advisable to take off the chain and guide bar and place in oil overnight. When not in use keep all chain sets continually in a bath of thick oil. Remove the roller bearing "N," Fig. 3, from the guide bar occasionally and thoroughly clean.

CHAIN GRINDER

The mortise chains should be sharpened with an oil stone slip on the face "O" only, Fig. 7. Care being taken to sharpen square across each link. When this is no longer adequate and to bring the chain cutters into correct angle for clean cutting they should be ground on the grinder, Fig. 6.

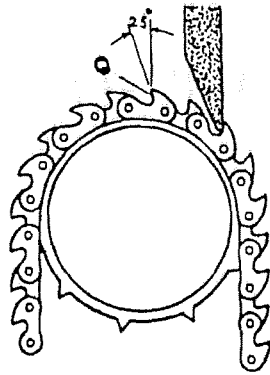

Fig. 7.

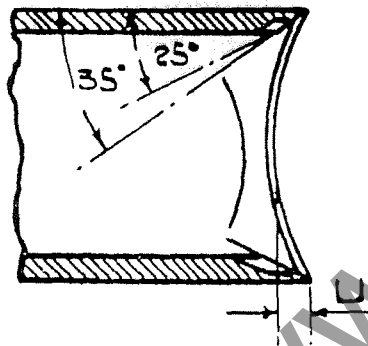

Fig. 8

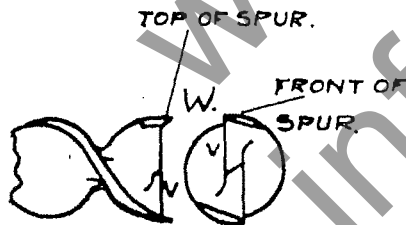

Fig. 9

The grinder is driven by belt from the small pulley at the rear of the main column. Remove the belt when the grinder is not in use. The sleeve "P" is adjusted by nuts "Q" and "R" until the grinding wheel lightly touches the face of the link at the correct angle, as shown at Fig. 7. Each link must be ground on the face only and not too deep in the gullet, care being taken to always retain the angle as when new. On no account must the sides be ground. As the grinding wheel is reduced in diameter, the slide is adjusted in slot "S" and locked by nut "T," the fine adjustment being given by nuts "Q" and "R," Fig. 6. As a link is ground by sliding the sleeve "P" along the bar each successive one is brought into position for grinding by the spring ratchet wheel. The sprocket wheels carrying the chain on sleeve "P" are adjustable to accommodate varying widths of chain. Three pairs of these sprockets are supplied with the grinder for various sizes of chains.

SQUARE CHISELS AND BITS

The CHISEL must be sharpened on the inside only and the cutting edges should be shaped to give a curve, shown at Fig. 8, and maintained in a shape as new. Never file the outside as this will reduce the size of the mortise. The bevels of the cutting edges must meet exactly at the corners. The depth "U" from the corner point to the curve at the centre should be about one-eighth the diameter of the size of the chisel. The cutting edges must be as short as possible and filed to an angle of about 35°, as shown at Fig. 8. The part behind the cutting edges must then taper off to an angle of 25°. It is recommended that the special Tool illustrated overleaf is used to ensure the correct angle on all four cutting edges of the chisel.

The BIT is sharpened by filing above the cutting edges "V," keeping the file at an angle of 15°. They must be kept in a straight line with the inside points extending past the centre, as shown at Fig. 9. The spurs "W" must be sharpened on the top and front only, never on the outside. They must be kept in line with the cutting edges "V." When a bit is worn away by frequent sharpening, replace by a new one, otherwise the square chisel may be split at the cutting edge. Use a file of very fine grade for sharpening both chisels and bits.

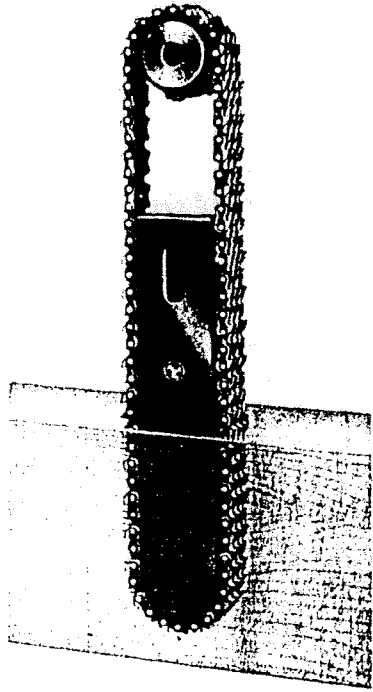

NEW TOOLS AND REPLACEMENTS

We can supply most sizes of chain sets and square hollow chisels from stock.

Users are advised to obtain these direct from us to ensure fitting the machine correctly.



BORING BIT. Although the machine is primarily used to mortise square or rectangular to receive the tenon joint, it can be used should occasion arise to drill holes up to a maximum of 1" diameter, 5½" deep. The illustration shows a two-fluted centre bit with $\frac{1}{2}$ " shank to fit the chisel spindle, which is the type recommended for the purpose.

SHARPENER FOR HOLLOW MORTISE CHISELS

This tool has been specially produced to enable mortise chisels to be kept always properly sharpened. It is used in an ordinary joiner's brace, and is maintained centrally with the axis of the chisel by means of a pilot which fits the bore of the chisel.

This ensures all four cutting edges being ground to the correct angle. Only the corners of the chisel require to be finished off with a file.



FILES FOR MORTISE CHISELS AND BITS.

This is the set of special files recommended for sharpening the square chisels and bits. They are a very fine grade and shaped to sharpen efficiently, the corners of the chisels after using the brace tool shown above.



WHEELS FOR MORTISE CHAIN GRINDER.

The 4" diameter wheel illustrated, Grade No. A.60 M.V. is used on the Chain Grinder for sharpening the mortise chains. It is essential to true up the wheel with a grinding wheel dresser, when running at the normal speed, before being used. The edge must be dressed to the desired thickness to suit the links of the mortise chain.

REPAIR TOOLS FOR MORTISE CHAINS

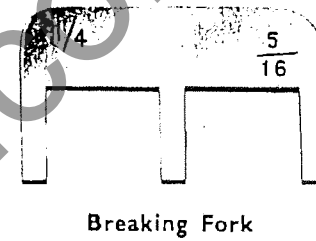
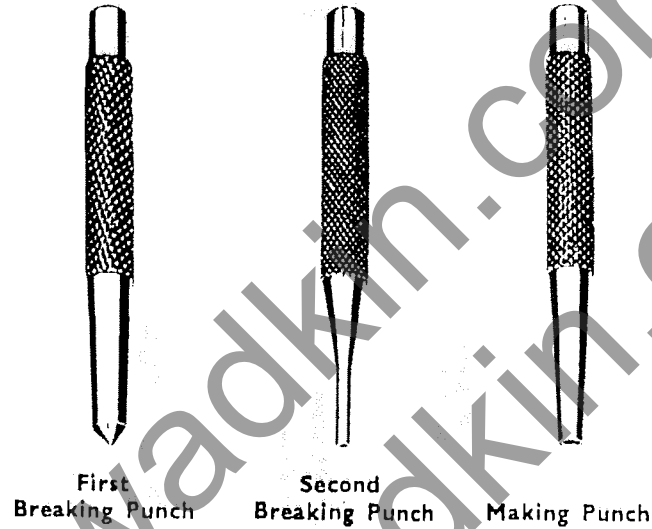
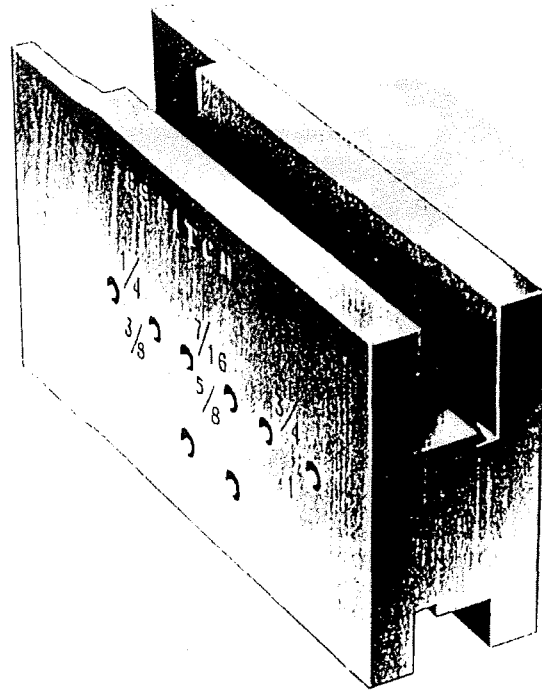

- ONE SET OF TOOLS COMPRISES:—
- (1) One anvil block
 - (2) First breaking punch
 - (3) Second breaking punch
 - (4) Making punch
 - (5) Breaking fork

NOTE.— One set of tools is necessary for each pitch of mortise chain.

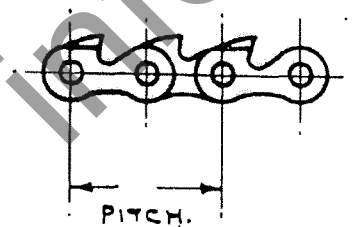

- 54" pitch.
- 62" pitch.
- 89" pitch.

INSTRUCTIONS FOR REPAIRING MORTISE CHAINS

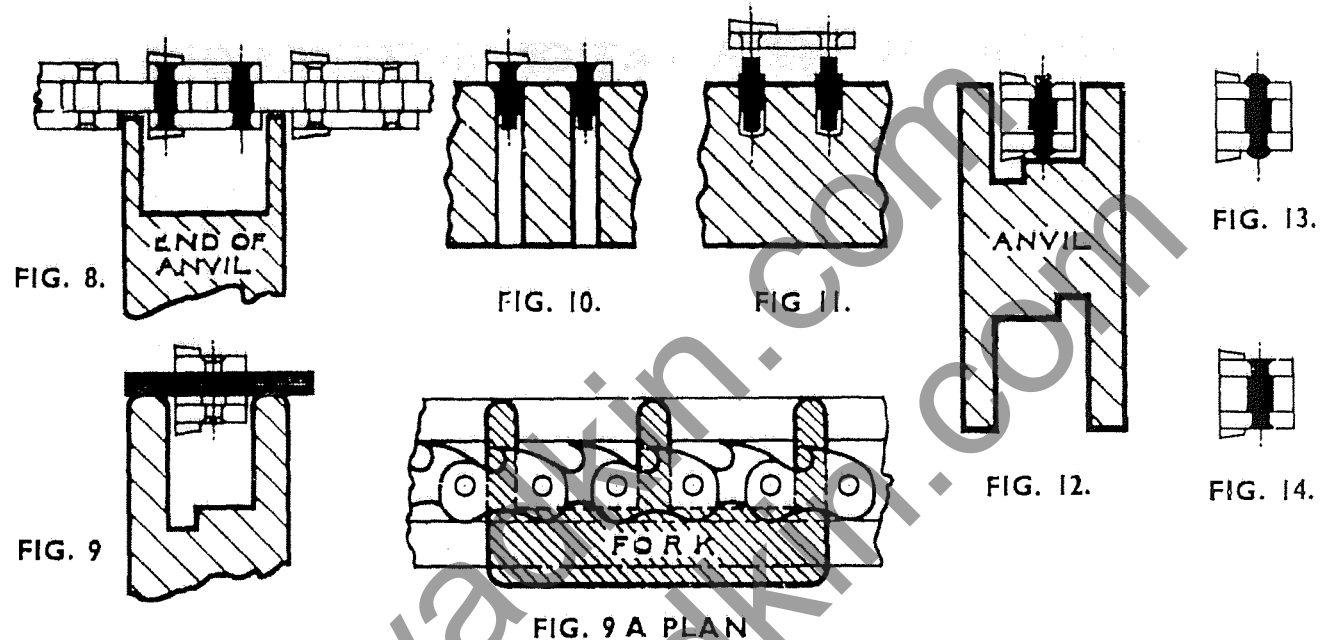

TO REMOVE BROKEN LINKS

It is important to grind flat all rivet heads before driving out rivets.

2. Place chain on anvil block fig. 8 and drive a little with "first breaking punch" on each rivet, allowing both to be driven out together with bottom side link.
3. Drive rivets right through with "second breaking punch." NOTE. Shouldered rivets will not permit pins driven out separately. Due to fragile links on $\frac{1}{4}$ " and $\frac{5}{16}$ " wide chains use "breaking fork" figs. 9 and 9/A for support of chain by placing over narrow deep — groove in anvil.
4. Place side link on anvil block fig. 10 and use "first and second breaking punches" to remove rivets.

TO ASSEMBLE CHAIN

5. Set rivets in one pair of blind holes in anvil block fig. 11 and tap outer link on to heads of rivets, afterwards carefully pean over rivet heads with light hammer.
6. Assemble links with necessary centre and outer links.
7. Place chain along groove of anvil block fig. 12 and support the overhanging end. The chain must be placed in the groove to give maximum support. The deep groove for wide chains and shallow one for narrow chains.
8. Carefully rivet down or swell out heads of rivets fig. 13. with the "making punch" which must be used for finishing only.
9. Grind down rivet heads to finish similar to remainder of chain fig. 14.

Before using a repaired chain carefully grind any new links to the same amount of gullet as the remainder of the chain.

ELECTRICAL INSTALLATION INSTRUCTIONS

INSTALLATION

The cabling between the motor and control gear has been carried out by WADKIN LTD. and it is only necessary to bring the line leads to the machine for it to be put into service. This should be done as follows :

- (1) Connect the line leads to the appropriate terminals of the Isolating switch. See diagram of connections. The cables should be taken to the machine in conduit and secured to the control apparatus by means of locknuts.
- (2) Ensure that the machine is connected solidly to earth.
- (3) Close the isolating switch and lower the appropriate hand lever. If the headstock motors do not rotate in the right direction, interchange any two incoming line leads.

FAILURE TO START

- (1) Electric supply is not available at the machine.
- (2) Fuses have blown or have not been fitted.
- (3) Isolating switch has not been closed.
- (4) Hand lever has not been sufficiently lowered.

STOPPAGE DURING OPERATION

- (1) Fuses have blown.
- (2) Overloads have tripped. They will reset automatically after a short time and the machine can be restarted in the usual manner.

ADJUSTMENTS

For a finer overload setting, set the load indicator to a lower value and vice-versa for a less fine setting.

GENERAL

Check the earth connection periodically. Users are recommended to display in a prominent position in the Maintenance Department, WADKIN ELECTRICAL MAINTENANCE INSTRUCTION CARD No. 356, which will be issued gratis on application.

RETAIN THIS DIAGRAM FOR FUTURE REFERENCE.

FOR PARTICULARS OF WADKIN PORTABLE BLOWER FOR CLEANING M/C. AND ELECTRICAL GEAR, SEE LEAFLET N° 687.

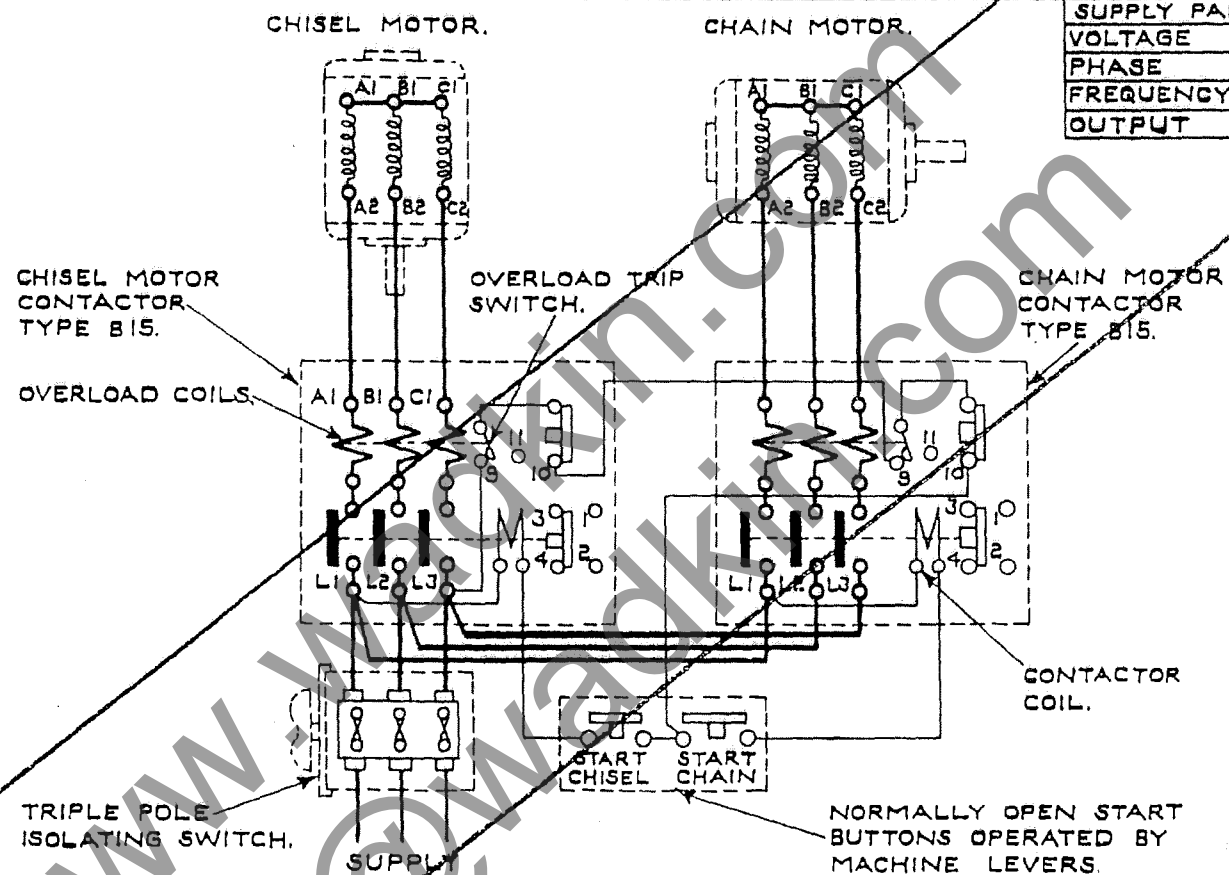

SUPPLY PARTICULARS	
VOLTAGE	
PHASE	
FREQUENCY	
OUTPUT	

INSTALLATION INSTRUCTIONS.

BRING SUPPLY CABLES L1-L2-L3 TO ISOLATING SWITCH THROUGH CONDUIT WHICH SHOULD BE SCREWED INTO THE MACHINE FRAME AND SECURED BY MEANS OF LOCKNUTS. A HOLE IS PROVIDED IN THE MACHINE FRAME FOR THE CONDUIT CARRYING THE SUPPLY TO THE ISOLATOR. ENSURE THAT THE DIRECTION OF ROTATION OF THE MOTORS IS CORRECT BEFORE PUTTING THE MACHINE INTO SERVICE. TO REVERSE ROTATION INTERCHANGE L1 & L3 AT ISOLATOR.

OVERLOAD.

SHOULD THE MOTORS STOP DUE TO OVERLOAD, RETURN THE MACHINE LEVERS TO THE NORMAL POSITION. WAIT FOR A SHORT TIME TO ALLOW THE TRIP SWITCH TO RESET ITSELF. THEN START IN THE USUAL MANNER.

WADKIN LTD.
LEICESTER.

DIAGRAM OF CONNECTIONS.

D.547.

COMBINED CHAIN & CHISEL MORTISING MACHINE. — TYPE M.F.

DIMENSIONS GIVEN IN FEET, INCHES & MILLIMETRES.

NOTE:— LIFTING RING TO BE
REMOVED AFTER MACHINE
IS FIXED. PLEASE RETURN
IT TO WADKIN LTD.

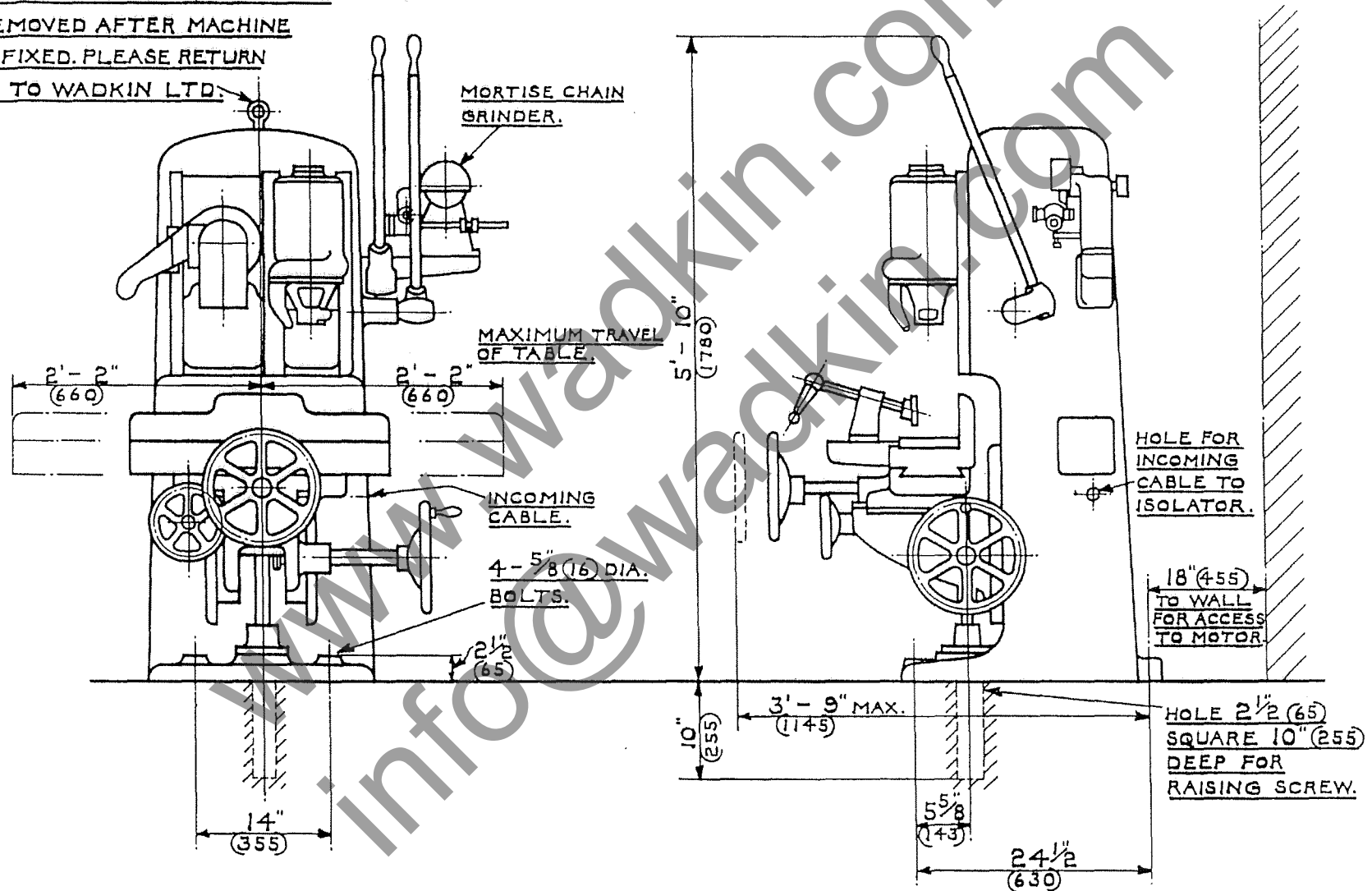

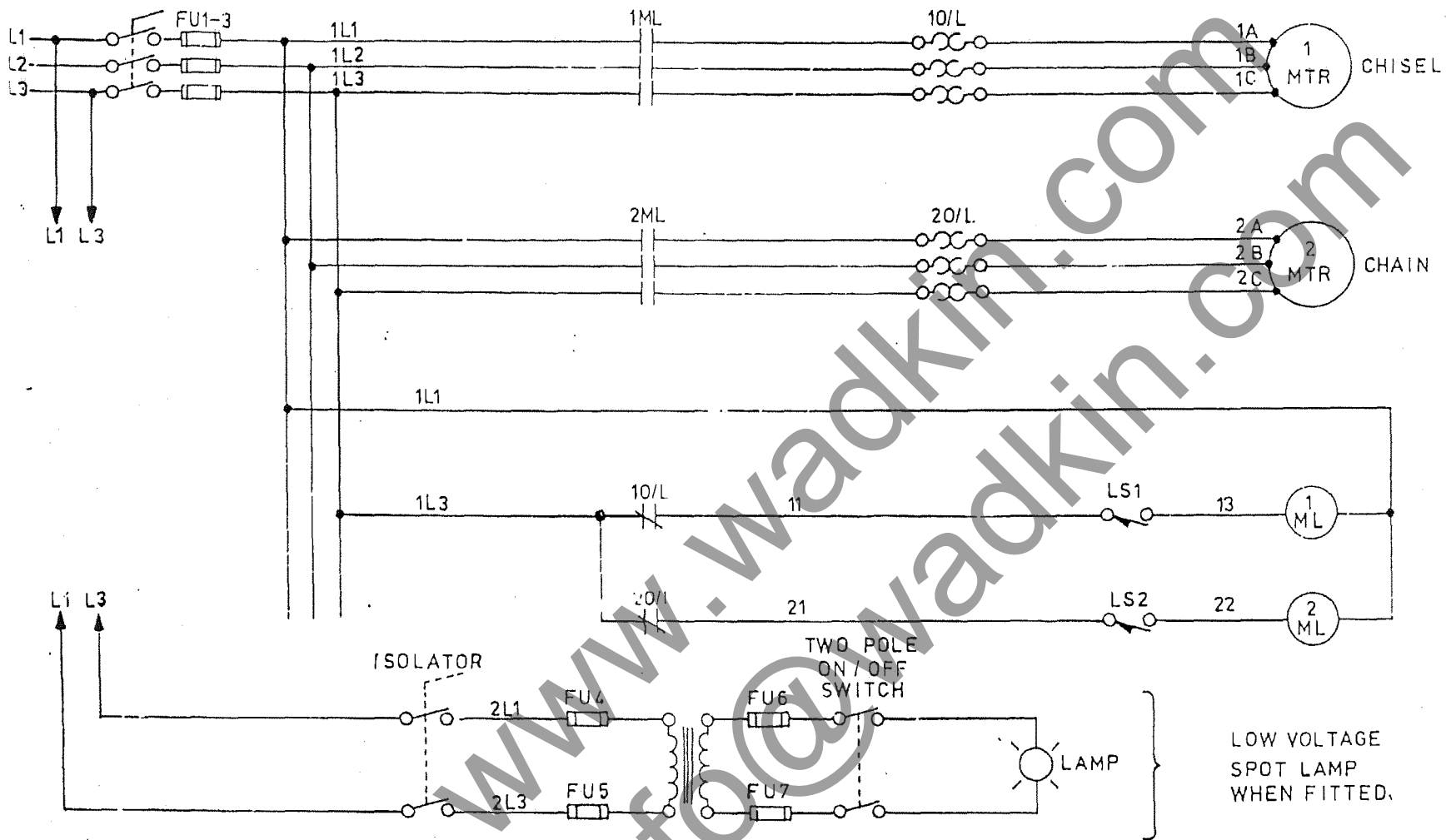

PART No.

SIMILAR TO

THIRD ANGLE PROJECTION

WADKIN LTD. LEICESTER

SURFACE FINISH
 ▽ - ROUGH M/C.
 W - FINISH M/C.
 WW - ROUGH GRIND
 WW - FINISH GRIND

IMPERIAL LIMITS
 FRACTIONS ± 1/16"
 DECIMALS ± .005"
METRIC LIMITS
 WHOLE NUMBERS = ± 1 M/M
 DECIMALS = ± 0.1 M/M
 BALL BEARING LIMITS - SEE LIST

DATE _____ SIG. _____
 ALT No. _____ D _____ C _____ B _____

DATE _____ A _____
 DRN. BY R.D.N.
 CHKD. BY _____
 DESCRIPTION
 D.O.L. CHAIN AND CHISEL
 MOTORS, OPERATED BY
 LIMIT SWITCHES.

QTY. _____ MATERIAL _____
 PART No.
D2165



... blow away harmful dust, chips and dirt with a Wadkin Electric Blower

No motor can run at its maximum efficiency with its ventilating duct or control gear covered with dust and dirt. Sooner or later the resultant overheating will cause serious trouble.

Similarly, accumulations of chips and dust, in the mechanical parts of the machine can interfere with its efficiency. A few minutes a week for blowing down all Woodworking Machinery will be amply repaid in better and easier running, in increased life, and freedom from breakdown.

Blowers can be supplied for single phase A.C. or Direct Current for any voltage up to 250.

Please state voltage when ordering.



FOR REPLACEMENT PARTS, TOOLS AND ACCESSORIES

CONTACT SPARE PARTS DEPARTMENT

WADKIN GREEN LANE ROAD

LEICESTER

LE5 4PF

TEL NO : (44) 0116 2769111

FAX NO : (44) 0116 2461021

www.wadkin.com
info@wadkin.com



SPARE PARTS BOOKLET

CONTENTS

1. Basic ordering requirements.
2. Sample type order.
3. List of item numbers and description of item.
4. Drawing showing item numbers.

MF

COMBINED CHAIN AND HOLLOW

CHISEL MORTISER

SPARE PARTS

Should spare parts be required due to breakage or wear full particulars including the machine and test number must be given. This information is on the nameplate attached to the machine and will be similar to the picture below.

Wackin Ltd.
LEICESTER ENGLAND

MACHINE SERIAL NO.	FD 5154	
MACHINE TEST NO.	73601	
PATENT NO.		
VOLTAGE	PHASE	CYCLES
400	3	50

SEE MAINTENANCE INSTRUCTION
BOOK FOR LUBRICATION DETAILS

Please see the next page for sample detail of how to order spare parts.

SAMPLE TYPE ORDER

MACHINE: MF

MACHINE NO: 1407

TEST NO: 68975

PARTS REQUIRED

1 - MF252/MF2 CHAIN SLIDE
1 - MF252/MF17 COVER FOR SPRING DRUM
1 - MF252/MF108 RACK FOR CHAINSLIDE
1 - MF252/MF124 CENTRE SLIDE STRIP
1 - MF252/MF141 CHIPBREAKER

MF SPARE PARTS LIST

MF252/MF1/B	MAIN FRAME
MF252/MF2	CHAIN SLIDE
MF252/MF4	CHAIN STATOR FRAME
MF252/MF5	BRACKET FOR GUIDE BAR HOLDER
MF252/MF6	IMPELLER FOR CHAIN FAN
MF252/MF8	CHISEL STATOR FRAME
MF252/MF9	CHISEL HOLDER
MF252/MF10	BEARING END SHIELD FOR CHISEL STATOR FRAME
MF252/MF11	IMPELLER FOR CHISEL FAN
MF252/MF12	OUTLET PIPE FOR CHISEL FAN
MF252/MF14	GEAR SEGMENT FOR CHISEL SLIDE
MF252/MF15	BOSS FOR CHISEL LEVER
MF252/MF16	C/BALANCE SPRING DRUM
MF252/MF17	COVER FOR SPRING DRUM.
MF252/MF19	END CAP FOR CHISEL STATOR FRAME
MF252/MF21	BOSS FOR CHAIN LEVER
MF252/MF28	GUARD FOR MORTISER
MF252/MF29	FRONT COVER FOR CHAIN SLIDE
MF252/MF30	OUTLET PIPE FOR CHAIN FAN.
MF252/MF33	SPINDLE FOR COUNTERBALANCE CHAIN GUIDE PULLEY
MF252/MF101	CHAIN ROTOR SPINDLE
MF252/MF102	DRIVING COLLAR FOR CHAIN SPROCKET
MF252/MF104	$\frac{1}{4}$ " - $\frac{1}{8}$ " - $\frac{1}{16}$ " SPACING COLLARS FOR CHAIN SPROCKETS
MF252/MF105	GREASE RETAINERS FOR CHAIN ROTOR SPINDLE
MF252/MF106	DISTANCE SLEEVE FOR CHAIN ROTOR SPINDLE
MF252/MF108	RACK FOR CHAINSLIDE
MF252/MF109	GUIDE BAR HOLDER
MF252/MF110	STUD FOR GUIDE BAR HOLDER
MF252/MF111	ADJ. NUT FOR GUIDE BAR HOLDER

MF252/MF114	LOCATING STRIP FOR GUIDE BAR BRACKET
MF252/MF115	NUT FOR GUIDE BAR BRACKET STUDS.
MF252/MF116	ADJUSTABLE UPPER STOP FOR CHAINSLIDE
MF252/MF117	EXTENSION PLATE FOR CHAINSLIDE STOP
MF252/MF120	CHISEL ROTOR SPINDLE (UNIT 26/15)
MF252/MF121	SPACING SLEEVE FOR CHISEL ROTOR SPINDLE
MF252/MF122	RACK FOR CHISEL SLIDE
MF252/MF123	STOP STRIP FOR CHISEL SLIDE
MF252/MF124	CENTRE SLIDE STRIP
MF252/MF125	ADJ. SLIDE STRIP
MF252/MF126	TOP DEAD STOP FOR SLIDES
MF252/MF127	HANDLEVER FOR CHAINSLIDE
MF252/MF128	HANDLEVER FOR CHISEL SLIDE
MF252/MF130	CHISEL GEAR SEGMENT SPINDLE
MF252/MF132	SPINDLE FOR CHAIN COUNTERBALANCE DRUM
MF252/MF134	RATCHET FOR COUNTERBALANCE DRUM SPINDLE
MF252/MF135	PAWL FOR COUNTER BALANCE RATCHET
MF252/MF136	STUD FOR COUNTER BALANCE PAWL
MF252/MF137	COUNTER BALANCE CHAIN FOR CHAINSLIDE
MF252/MF138	COUNTER BALANCE CHAIN FOR CHISEL SLIDE
MF252/MF140	COUNTER BALANCE SPRING
MF252/MF141	CHIPBREAKER
MF252/MF148	PLUNGER FOR LEVER CLIP
MF252/MF150	STANDARD $\frac{5}{8}$ " HEX NUT MODIFIED FOR CHAIN SPINDLE
MF252/MF159	FULCRUM SHAFT FOR GUARD
MF252/MF161	KEEP PLATE
MF252/MF172	CHAIN GEAR SEGMENT SPINDLE
MF252/MF174	RUBBER BUSH
MF252/MF199	REAR COVER FOR MAIN FRAME

MF252/MA112	GREASE RETAINER FOR ROTOR SPINDLE
MF252/MA114	GRINDER DRIVING PULLEY FOR ROTOR SPINDLE
MF252/MD86	PAD FOR STOP STRIP
MF252/ME24	TABLE SLIDE
MF252/ME25	KNEE BRACKET FOR TABLE
MF252/ME27/A	NUT FOR TABLE SLIDE
MF252/ME29	BUSH FOR TABLE KNEE BRACKET
MF252/ME41	VEE STRIP FOR TABLE SLIDE
MF252/ME45	GEAR SEGMENT FOR CHAIN SLIDE
MF252/ME56	GUIDE PULLEY FOR CHISEL WEIGHT
MF252/ME58	COLLAR FOR CLIP
MF252/ME59	BRACKET FOR LEVER STOP
MF252/ME82	SLIDE STRIP FOR KNEE BRACKET
MF252/ME83	SLIDE STRIP FOR TABLE
MF252/ME85	MITRE WHEEL SHAFT
MF252/ME88	PINION SHAFT
MF252/ME89	TABLE SCREW
MF252/ME90	COLLAR FOR TABLE SCREW
MF252/ME91	RAISING SCREW
MF252/ME92	STRIP FOR TABLE SCREW
MF252/ME101	CRAMP SCREW
MF252/ME102	KEEP PLATE FOR GUIDE BAR
MF252/ME126	CLIP FOR OPERATING LEVER
MF252/ME130	STOP FOR OPERATING LEVER
MF252/ME136	LEVER PLUNGER SPRING
MF252/ME160	BRACKET FOR RAISING SCREW
MF252/ME174	SPECIAL WASHER FOR CRAMP PLATE
MF252/ME211	BRACKET FOR CYLINDER
MF252/ME212	CRAMP NUT

MF252/ME213	CRAMP PLATE
MF252/ME219	TABLE
MF252/ME250	STOP STRIP FOR VERTICAL SLIDES
MF252/ME261	ADJ. STOP FOR VERTICAL SLIDES
MF252/ME262	DEAD STOP
MF252/ME290	GUIDE ROD FOR CLAMP PLATE
MF252/ME303	LOCKING BOLT
MF252/ME331	PINION
MF252/ME332	RACK FOR TABLE
MF252/MEG6	FRONT EMERY WHEEL FLANGE
MF252/MEG51	PIVOT BRACKET
MF252/MEG52/A	GUARD
MF252/MEG62	PIVOT ROD
MF252/MEG63	ADJUSTING SLEEVE
MF252/MEG68	.62" PITCH CHAIN SPROCKET
MF252/MEG69	.89" PITCH CHAIN SPROCKET
MF252/MEG71	ADJUSTING SCREW
MF252/MEG72	LOCKNUT FOR ADJ. SCREW
MF252/MEG74	SPRING STOP
MF252/MEG77	COLLAR FOR PIVOT ROD
MF252/MEG78	NUT FOR ADJUSTING SLEEVE
MF252/MEG82	.54" CHAIN SPROCKET
MF252/MEG84	DISTANCE PIECE FOR GRINDING SPINDLE
MF252/MEG85	SPACING SLEEVE FOR GRINDING SPINDLE
MF252/MEG86	END CAP FOR GRINDING SPINDLE
MF252/MEG87	GRINDING SPINDLE
MF252/MEG88	PULLEY
MF252/MEG89	BACK EMERY WHEEL FLANGE
MF252/MEG91	CHAIN SPINDLE
MF252/MEG92	CHAIN HOLDER
MF252/MEG95	BODY

MF252/MEG96	BAR FOR ADJUSTING SCREW
MF252/1A	LOCKING HANDLE AND BRASS PAD
MF252/1A	LOCKNUT
MF252/1A	PIP SCREW
MF252/1A	SLIDE ADJ. SCREW
MF252/1B	DOOR KNOB
MF252/1B	LOCKNUT
MF252/2B	PIPSCREW
MF252/3B	HANDWHEEL
MF252/3D	LOCKNUT
MF252/4C	TWO BALL HANDLE
MF252/5B	HANDWHEEL
MF252/6B	COLLAR
MF252/7	COLLAR
MF252/9A	COLLAR
MF252/SKF 0.10	BEARING
MF252/SKF RL 13	BEARING
MF252/SKF RLS 4	BEARING
MF252/SKF RM 8	BEARING
MF252/SKF RM 9	BEARING
MF252/CL112	END COVER FOR STATOR FRAME
MF252/EK174	LOCKNUT FOR SLEEVE FOR STOP
MF252/QE5	MITRE WHEELS
MF252/UGW121	GRINDING WHEEL

SECRET REPRODUCTION

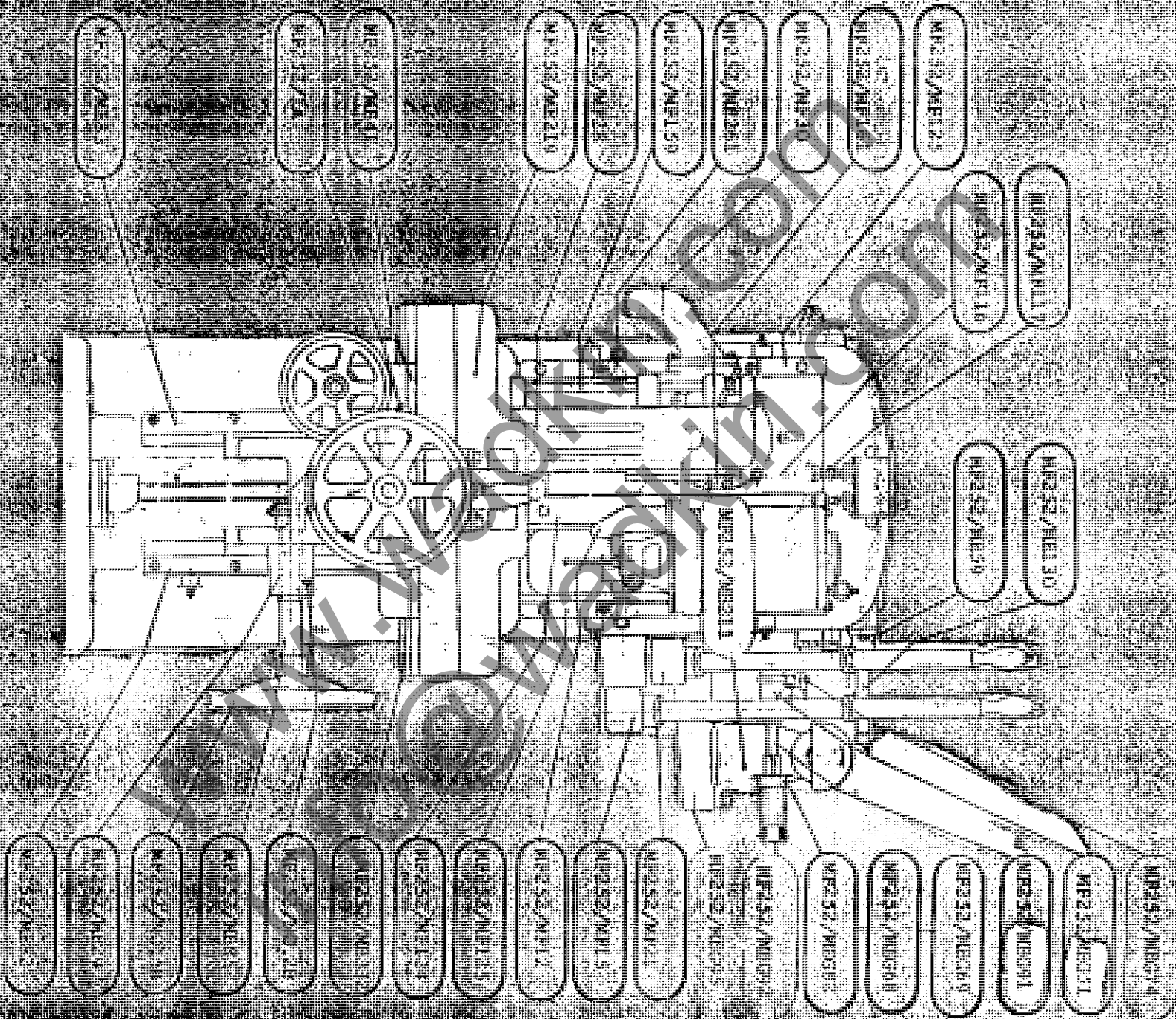

GENERAL DIMENSIONS

FOR DIMENSIONS OF THIS AND OTHER COMPONENTS

SECRET REPRODUCTION

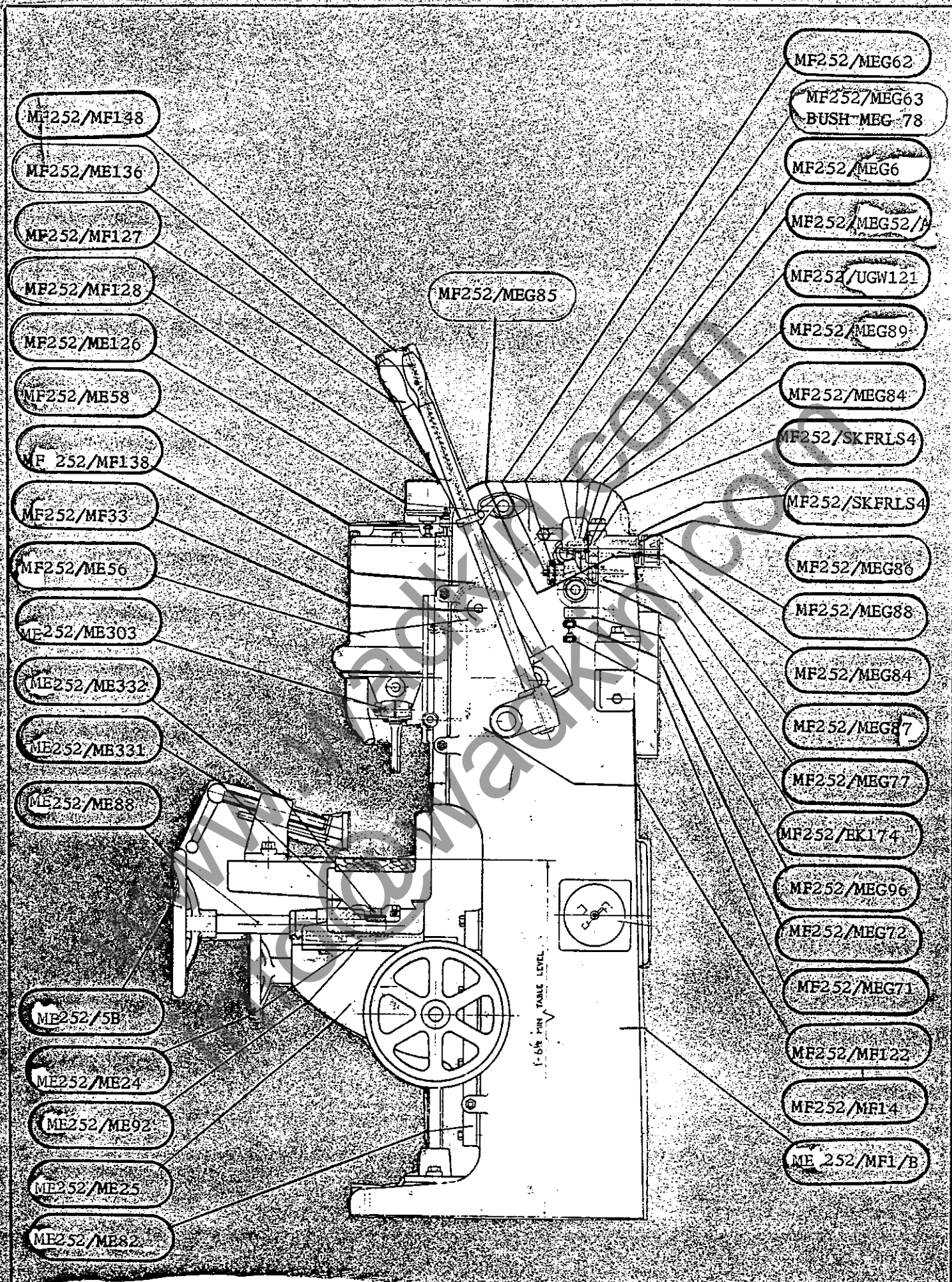

- MF252/MF148
- MF252/ME136
- MF252/MF127
- MF252/MF128
- MF252/ME126
- MF252/ME58
- MF252/MF138
- MF252/MF33
- MF252/ME56
- MF252/ME303
- MF252/ME332
- MF252/ME331
- MF252/ME88
- MF252/5B
- MF252/ME24
- MF252/ME92
- MF252/ME25
- MF252/ME82

MF252/MEG85

- MF252/MEG62
- MF252/MEG63
BUSH MEG 78
- MF252/MEG6
- MF252/MEG52/A
- MF252/UGW121
- MF252/MEG89
- MF252/MEG84
- MF252/SKFRLS4
- MF252/SKFRLS4
- MF252/MEG86
- MF252/MEG88
- MF252/MEG84
- MF252/MEG87
- MF252/MEG77
- MF252/EK174
- MF252/MEG96
- MF252/MEG72
- MF252/MEG71
- MF252/MF122
- MF252/MF14
- MF252/MF1/B

1-5/8" MIN. TABLE LEVEL

END ELEVATION OF RIGHT HAND SIDE OF M/C

ILLUSTRATION 2

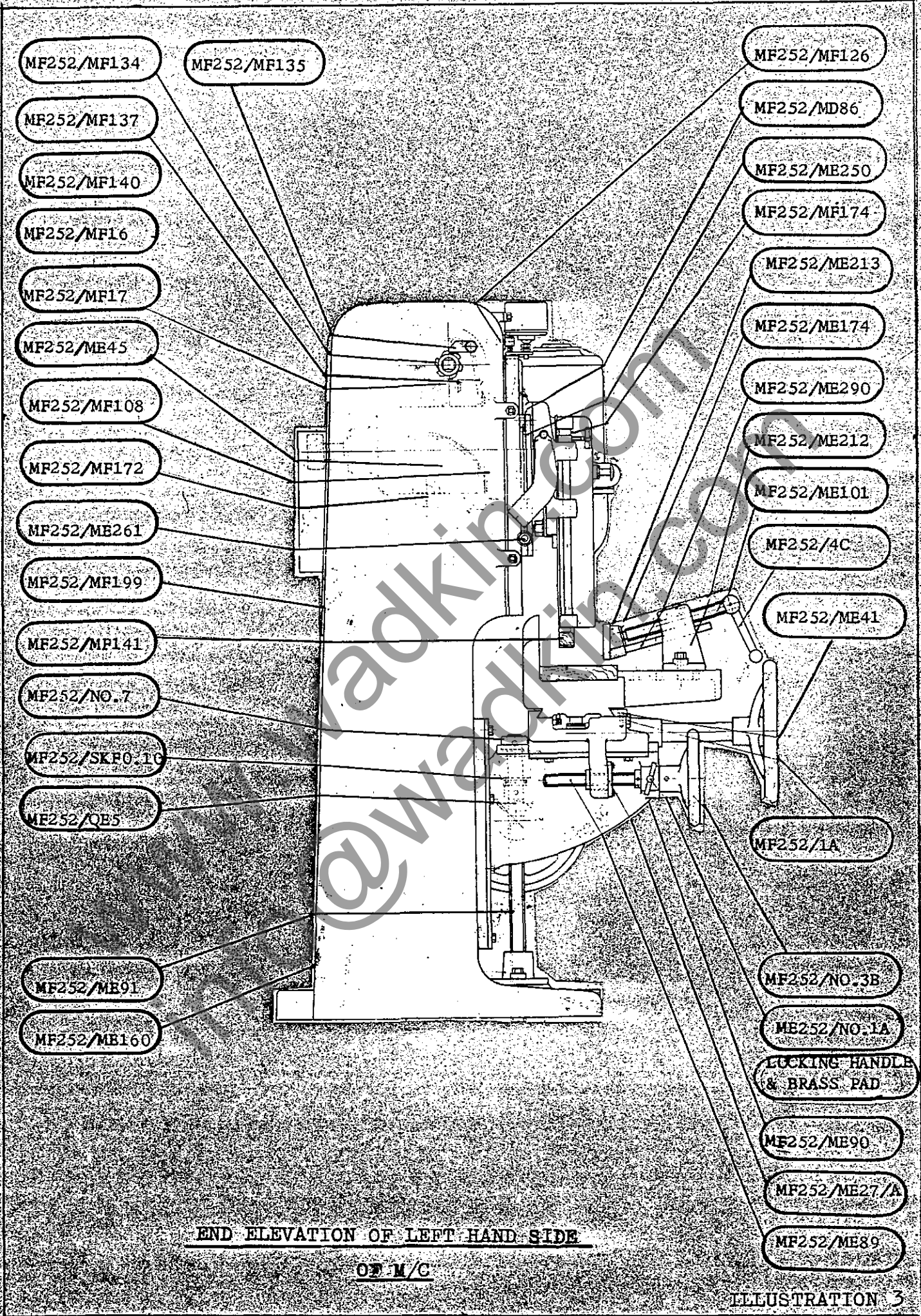

END ELEVATION OF LEFT HAND SIDE
OF M/C

SECTIONAL VIEW OF MOTOR

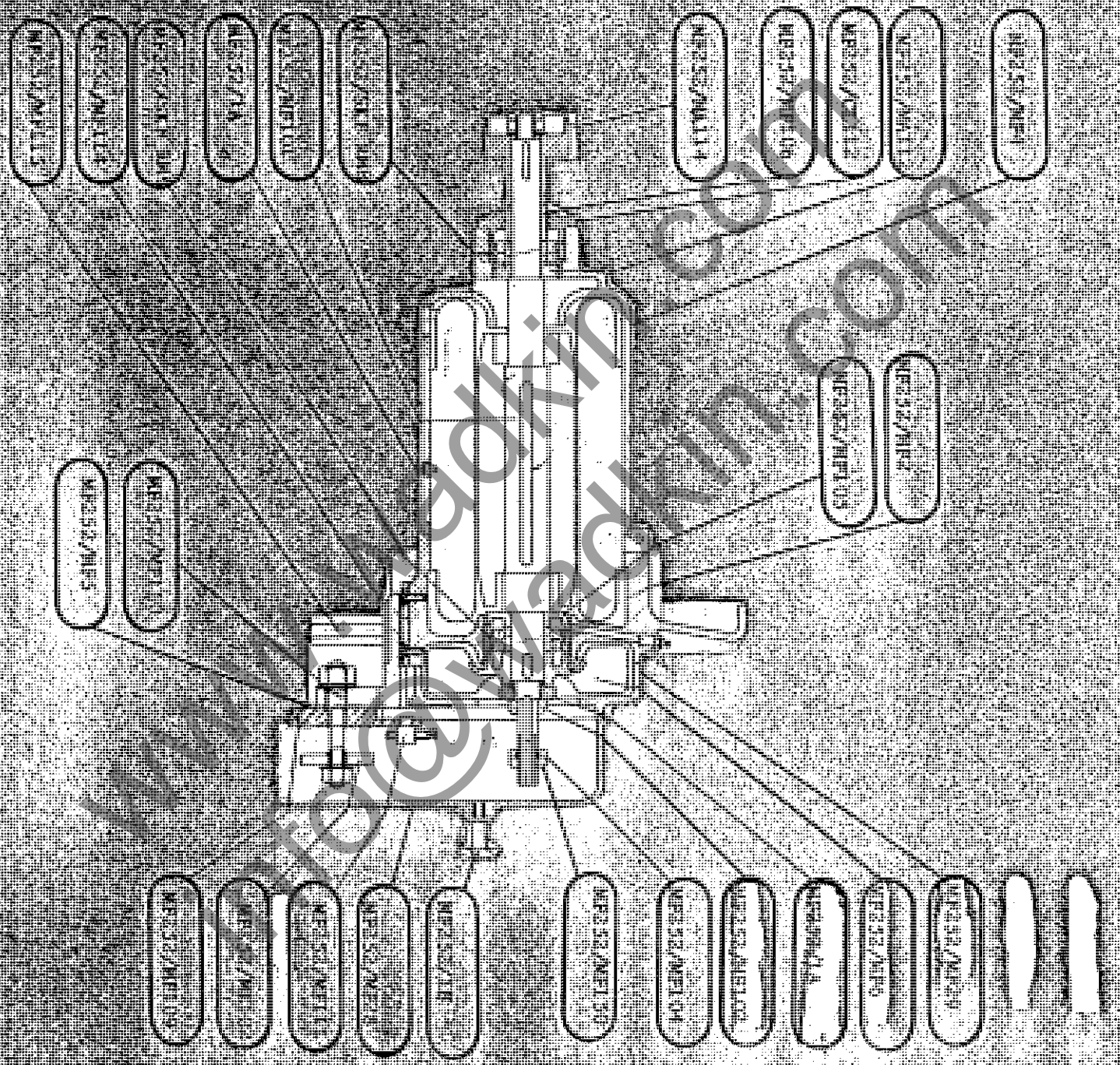



DETAIL OF SPINDLE END

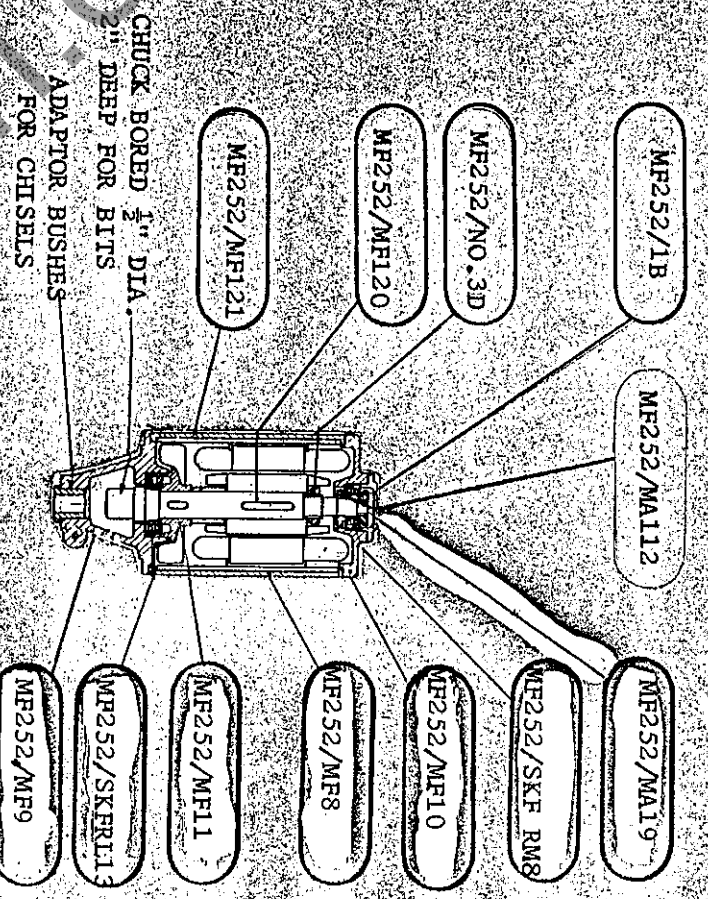

LAYOUT OF CHISEL MOTOR UNIT

2 HP UNIT WK 26/15

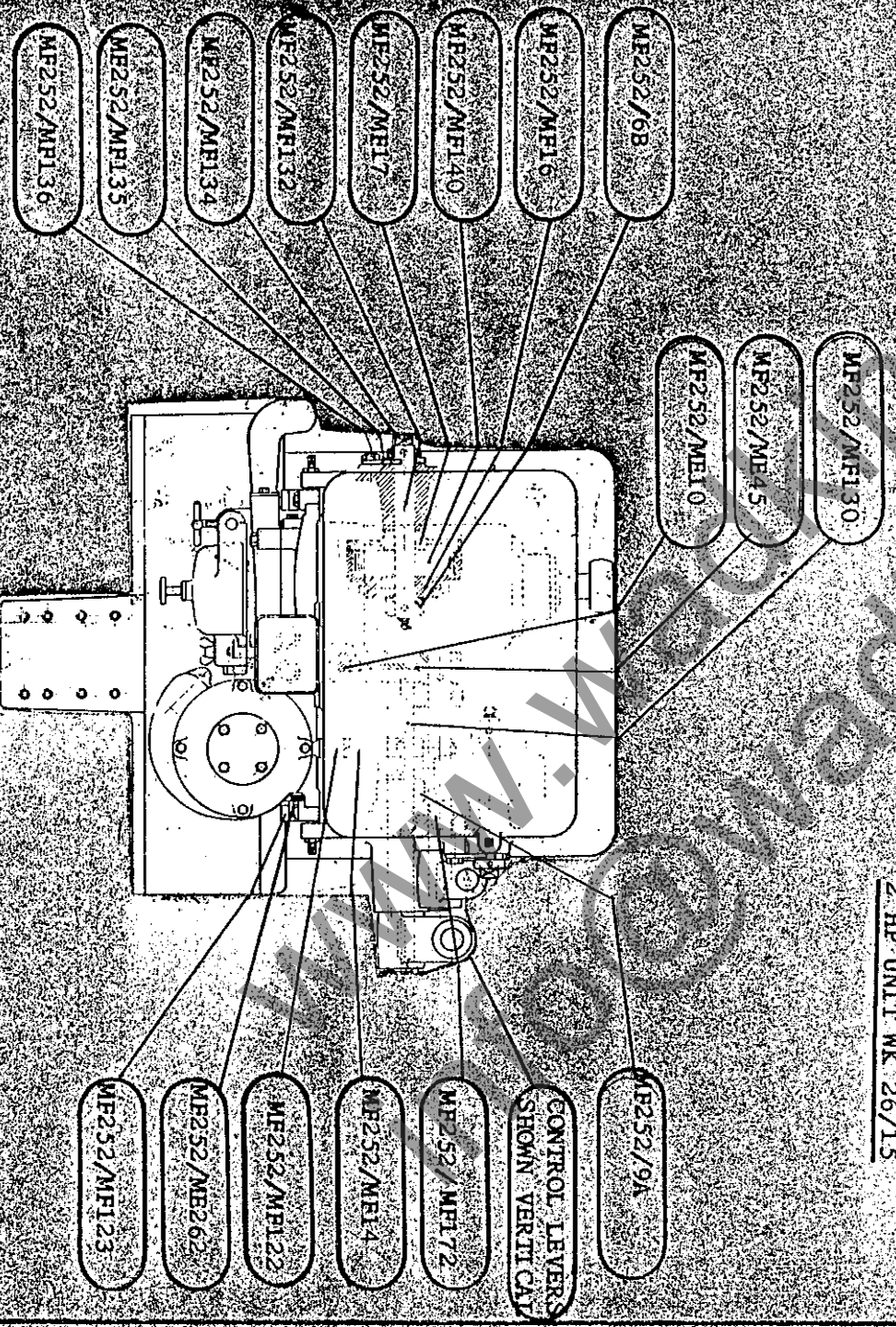

TOP ELEVATION OF MACHINE